

| PART NUMBER | REV | TERMINATOR | FEED TYPE | DESCRIPTION |
|-------------|-----|------------|----------------|--------------------|
| 1528608-1 | A | LEADMAKER | MECH POST FEED | CUTS CARRIER |
| 1528608-2 | A | BENCH | MECH PRE FEED | CUTS CARRIER |
| 1528608-6 | A | LEADMAKER | MECH POST FEED | CONTINUOUS CARRIER |
| 7-1528608-1 | A | LEADMAKER | MECH POST FEED | -1 AND SPARE PARTS |
| 7-1528608-2 | A | BENCH | MECH PRE FEED | -2 AND SPARE PARTS |
| 7-1528608-6 | A | LEADMAKER | MECH POST FEED | -6 AND SPARE PARTS |
| 7-1528608-7 | A | - | - | SPARE PARTS KIT |

| WIRE | SIZE | TYPE | RANGE |
|-------------------|--------------------------|------|------------------------------|
| WIRE | 2.54 [1.00 IN] | F | 1.50-2.50mm ² |
| INSUL | 3.94 [1.55 IN] | O | 2.10-2.90 [0.83-.114 IN] 1/4 |
| WIRE STRIP LENGTH | 4.00-4.60 [1.57-.181 IN] | | |

| TYCO TERM PN | MANUF TERM PN | TYCO SEAL PN | MANUF SEAL PN |
|--------------|---------------|--------------|---------------|
| 1572920-1 | 22124444640 | 1572281-2 | 10800472631 |
| 1572920-2 | 22125444640 | 1572798-1 | 10800444523 |
| 1572920-3 | 22140444640 | - | - |

| WIRE SIZE | CRIMP HEIGHT | REF SETTING |
|----------------------|-----------------------------|-------------|
| 2.50 mm ² | 1.80 ±0.05 [0.071 ±.002 IN] | B 5 |
| 1.50 mm ² | 1.50 ±0.05 [0.059 ±.002 IN] | D 5 |

- △ RECOMMENDED SPARE PARTS
- 2. GREASE RAM, CAM, CAM FOLLOWER AND FEED ROD LIGHTLY
- △ LUBRICATE DAILY PER THE APPLICATOR INSTRUCTION SHEET SUPPLIED WITH THE APPLICATOR
- △ THIS APPLICATOR APPLIES TERMINAL WITH A SEAL.
- △ APPLY TORO-SEAL IN ALLEN SOCKET TO FILL HOLE AFTER FLAT HD HAS BEEN ADJUSTED TO CORRECT HEIGHT AT QUALIFICATION. APPLY #1-23419-5 LOC-TITE TO THREADS.
- △ CRIMP HEIGHTS SUPPLIED BY TERMINAL MANUFACTURER.
- △ CUT TO LENGTH AT ASSEMBLY.

*** WARNING**
 ON INSTALLATION, SET WIRE DISC TO LARGEST WIRE SIZE SETTING. USE OF SETTINGS BELOW MIN. REQUIRED CRIMP HEIGHT SETTING WILL CAUSE DAMAGE TO CRIMP TOOLING.

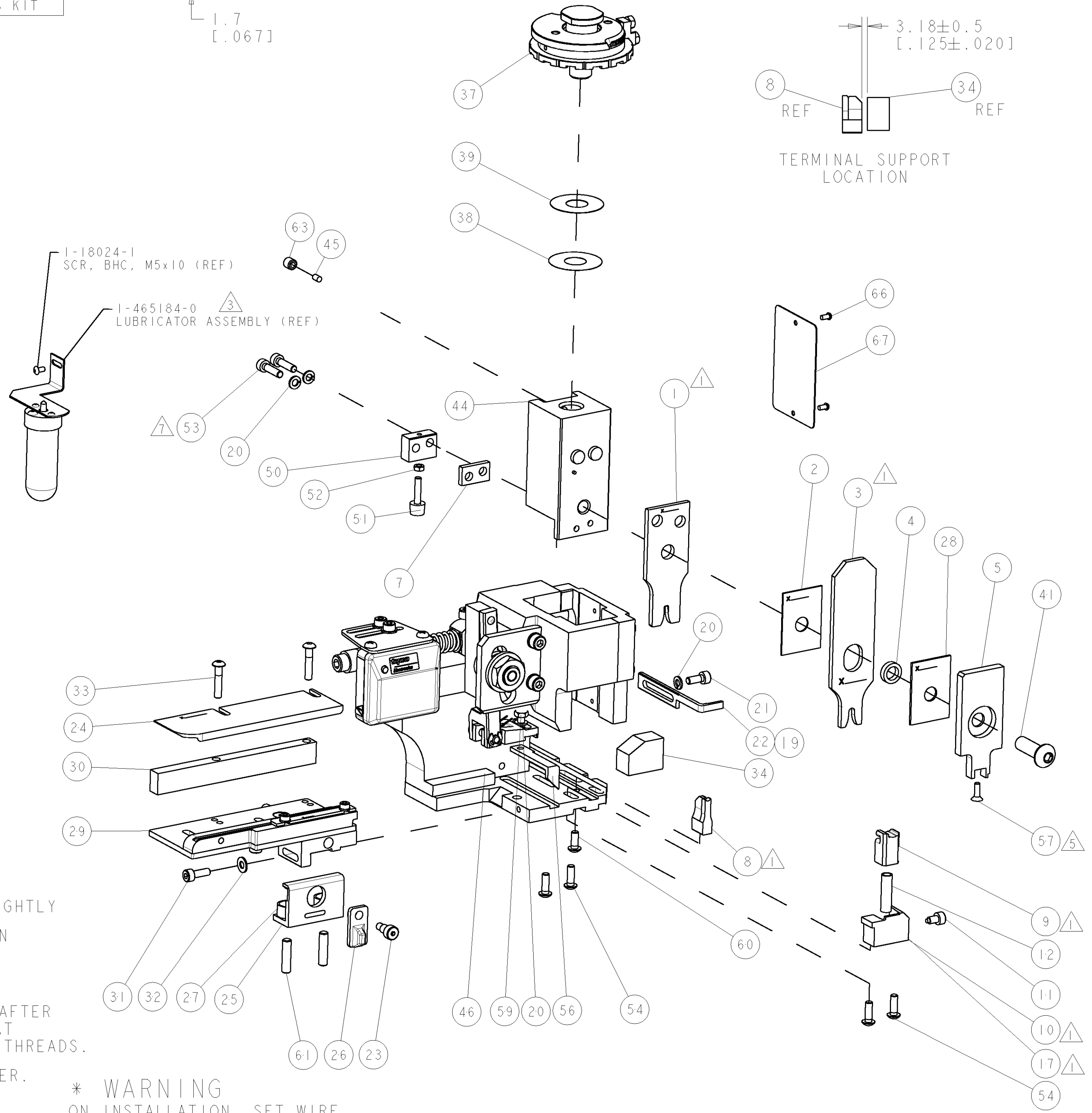
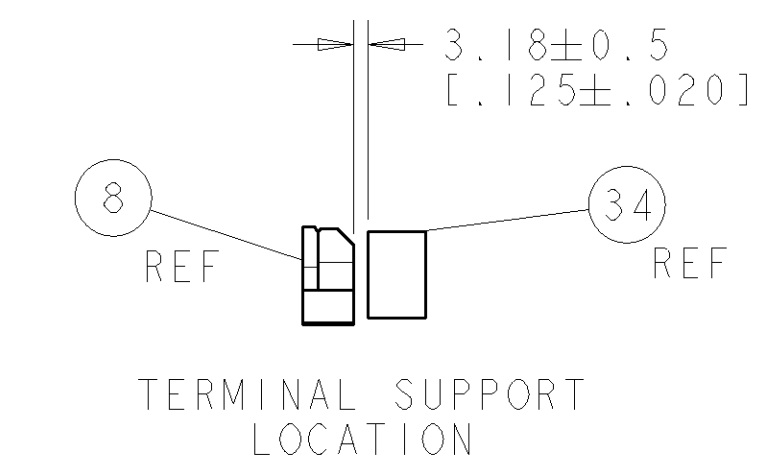
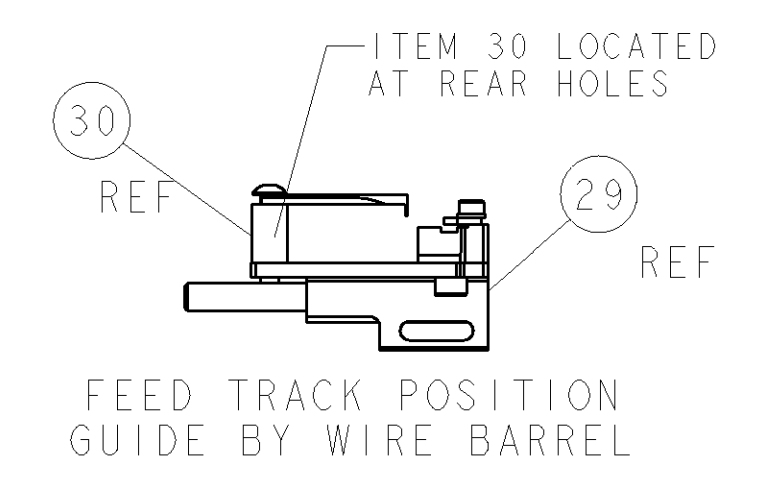
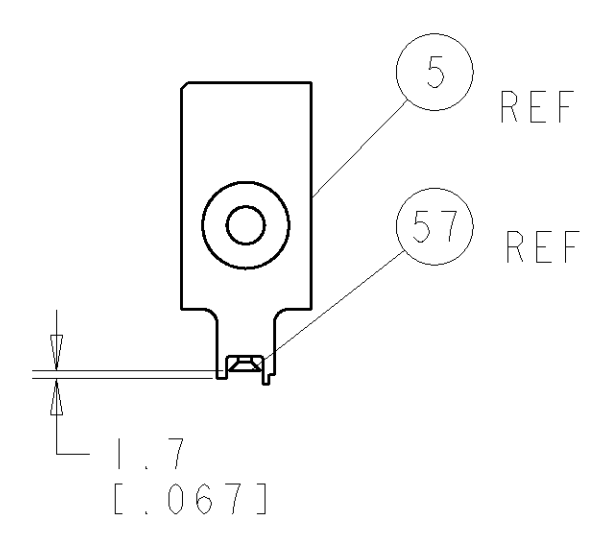
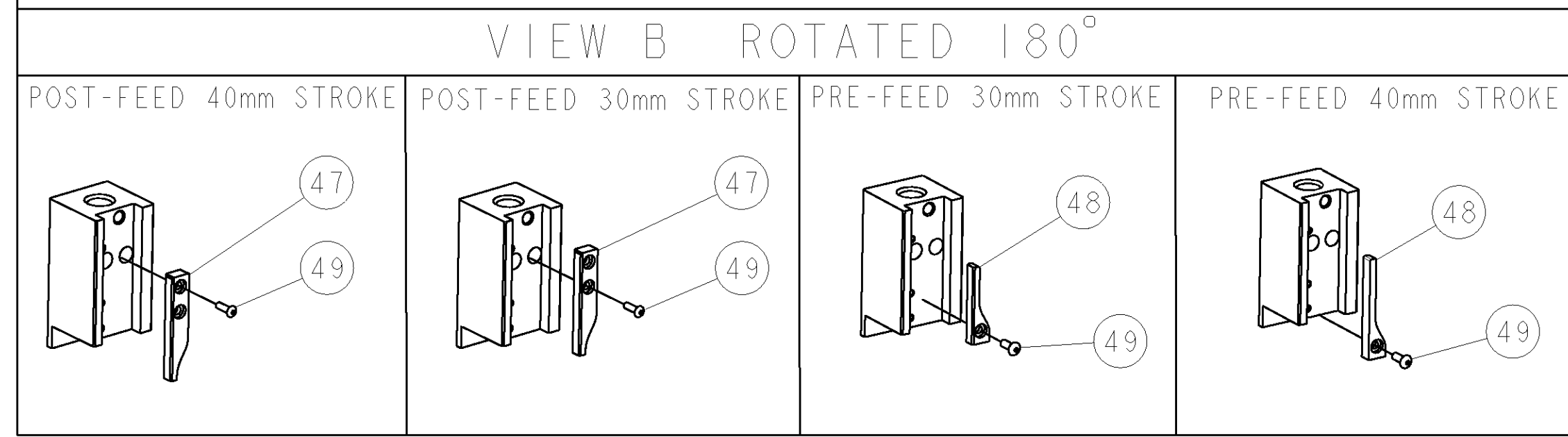

| SET UP GAGE 458637-3 | | LOC | DIST | REVISIONS | | | |
|----------------------|-----|-------------------|-----------|-----------|------|--|--|
| P | LTR | DESCRIPTION | DATE | BY | APPD | | |
| A | | SEE ECO-06-003406 | 15FEB2006 | LJL | MC | | |

| QTY | UNIT | PART NO | DESCRIPTION | ITEM NO |
|-----|------|---------|-------------|---------|
| - | - | - | - | 73 |
| - | - | - | - | 72 |
| - | - | - | - | 71 |
| - | - | - | - | 70 |
| - | - | - | - | 69 |
| - | - | - | - | 68 |
| - | - | - | - | 67 |
| - | - | - | - | 66 |
| - | - | - | - | 65 |
| - | - | - | - | 64 |
| - | - | - | - | 63 |
| - | - | - | - | 62 |
| - | - | - | - | 61 |
| - | - | - | - | 60 |
| - | - | - | - | 59 |
| - | - | - | - | 58 |
| - | - | - | - | 57 |
| - | - | - | - | 56 |
| - | - | - | - | 55 |
| - | - | - | - | 54 |
| - | - | - | - | 53 |
| - | - | - | - | 52 |
| - | - | - | - | 51 |
| - | - | - | - | 50 |
| - | - | - | - | 49 |
| - | - | - | - | 48 |
| - | - | - | - | 47 |
| - | - | - | - | 46 |
| - | - | - | - | 45 |
| - | - | - | - | 44 |
| - | - | - | - | 43 |
| - | - | - | - | 42 |
| - | - | - | - | 41 |
| - | - | - | - | 40 |
| - | - | - | - | 39 |
| - | - | - | - | 38 |
| - | - | - | - | 37 |
| - | - | - | - | 36 |
| - | - | - | - | 35 |
| - | - | - | - | 34 |
| - | - | - | - | 33 |
| - | - | - | - | 32 |
| - | - | - | - | 31 |
| - | - | - | - | 30 |
| - | - | - | - | 29 |
| - | - | - | - | 28 |
| - | - | - | - | 27 |
| - | - | - | - | 26 |
| - | - | - | - | 25 |
| - | - | - | - | 24 |
| - | - | - | - | 23 |
| - | - | - | - | 22 |
| - | - | - | - | 21 |
| - | - | - | - | 20 |
| - | - | - | - | 19 |
| - | - | - | - | 18 |
| - | - | - | - | 17 |
| - | - | - | - | 16 |
| - | - | - | - | 15 |
| - | - | - | - | 14 |
| - | - | - | - | 13 |
| - | - | - | - | 12 |
| - | - | - | - | 11 |
| - | - | - | - | 10 |
| - | - | - | - | 9 |
| - | - | - | - | 8 |
| - | - | - | - | 7 |
| - | - | - | - | 6 |
| - | - | - | - | 5 |
| - | - | - | - | 4 |
| - | - | - | - | 3 |
| - | - | - | - | 2 |
| - | - | - | - | 1 |

| QTY | UNIT | PART NO | DESCRIPTION | ITEM NO |
|-----|------|---------|-------------|---------|
| - | - | - | - | 83 |
| - | - | - | - | 82 |
| - | - | - | - | 81 |
| - | - | - | - | 80 |
| - | - | - | - | 79 |
| - | - | - | - | 78 |
| - | - | - | - | 77 |
| - | - | - | - | 76 |
| - | - | - | - | 75 |
| - | - | - | - | 74 |

| QTY | UNIT | PART NO | DESCRIPTION | ITEM NO |
|-----|------|---------|-------------|---------|
| - | - | - | - | 83 |
| - | - | - | - | 82 |
| - | - | - | - | 81 |
| - | - | - | - | 80 |
| - | - | - | - | 79 |
| - | - | - | - | 78 |
| - | - | - | - | 77 |
| - | - | - | - | 76 |
| - | - | - | - | 75 |
| - | - | - | - | 74 |